

**REFRIGERATOR MANUFACTURER**  
**Turbo air**  
 more durable, efficient, beautiful

4184 E. Conant St.  
 Long Beach, CA 90808  
 Tel. 310-900-1000  
 Fax. 310-900-1077  
[www.turboairinc.com](http://www.turboairinc.com)

Project :	
Model # :	
Item # :	Qty :
Available W/H :	
Approval :	

## Horizontal Open Display Cases

LOW PROFILE  
 GLASS SIDE PANEL

**TOP DISPLAY DRY CASES (OPTIONAL)**  
**NO PLUMBING REQUIRED**

**Model : TOM-60L(B)**



**TOM-60L**

- Top display dry cases is optional.



**TOM-60LB**



**NEW TOM-60LB-SF**

Stainless steel front panel  
 available (optional)

\* For the 'Stainless Steel Front (SF)' option, an additional \$350 will apply to the dealer's net price. This optional fee is not subject to dealer discounts.

### FEATURES / BENEFITS

■ **MODERN DESIGN**

By harmonizing curvature and rigidity, our modern style product designs are user-friendly while maintaining the highest product visibility and aesthetics.

■ **DESIGNED TO OPTIMIZE IMPULSE SALES**

Ideal for eye-catching displays and convenient access with fast service in high traffic area.

■ **ENVIRONMENTALLY FRIENDLY, EFFICIENT REFRIGERATION SYSTEM**

Turbo Air's refrigerators are designed with oversized and balanced environmentally friendly R-134A (CFC Free) refrigeration. These include large evaporators and condensers for faster cooling and balanced temperature throughout the cabinet.

■ **ATTRACTIVE GLASS SIDED ELEGANT EURO DESIGN**

Glass front shield and side walls optimize the merchandiser's display effects of fresh salads, sandwiches, desserts and beverages. Its elegant contemporary euro design will enhance any store application.

■ **NON-PEEL, DURABLE ANTI-RUST COATING ON THE EXTERIOR REDUCES FINGERPRINTS**

■ **STANDARD BACK-GUARD IMPROVES AIRFLOW**

■ **300 SERIES STAINLESS STEEL INTERIOR STANDARD INCLUDING BACK WALL, SHELVES AND DECK PANS**

■ **PERFORATED INTERIOR BACK WALL AND TOP FOR IMPROVED AIR FLOW**

■ **FRONT AIR INTAKE AND REAR AIR DISCHARGE**

■ **FOAMED WITH POLYURETHANE, HIGH-DENSITY CELL INSULATION (CFC FREE)**

■ **WHITE AND BLACK COLOR COME STANDARD**

■ **TOP DISPLAY DRY CASES (TOMD-L) AVAILABLE IN ALL SIZES (OPTIONAL)**

■ **STAINLESS STEEL FRONT PANEL AVAILABLE FOR ALL MODEL (OPTIONAL)**

■ **RECOMMENDED OPERATING CONDITIONS**

TOM models are designed to operate in an environment where temperature & humidity do not exceed 75°F and 55% respectively. Units should not be installed near HVAC vents, fans or doorways that will disrupt the air curtain and compromise the function of the cabinet. Air curtain models will run most efficiently when completely loaded with product.



Model	CU./FT.	# of Shelves	HP	AMPS	Crated Weight (lbs.)	L x D x H (inches)
<b>TOM-60L(B)</b>	<b>14.7</b>	<b>1</b>	<b>3/4</b>	<b>15.5</b>	<b>583</b>	<b>63 1/4 x 34 5/8 x 45 3/4</b>

# Horizontal Open Display Cases

LOW PROFILE  
GLASS SIDE PANEL

## Model : TOM-60L(B)

ELECTRICAL DATA	
Voltage	115/60/1
Plug Type	Ⓜ NEMA-5-20P
Full Load Amperes	15.5
Compressor HP	3/4
Refrigerant	R-134A
DIMENSIONAL DATA	
Net Capacity cu. ft.	14.7
Ext. Length Overall in.	63 <sup>1</sup> / <sub>4</sub> (1607mm)
Ext. Depth Overall in.	34 <sup>5</sup> / <sub>8</sub> (880mm)
Ext. Height Overall in.	45 <sup>3</sup> / <sub>4</sub> (1162mm)
Int. Length Overall in.	60 <sup>3</sup> / <sub>4</sub> (1543mm)
Int. Depth Overall in.	24 (610mm)
Int. Height Overall in.	17 <sup>1</sup> / <sub>2</sub> (445mm)
Gross Weight lbs.	448
Net Weight lbs.	583
# of Shelves	1
Self Size	60 <sup>3</sup> / <sub>4</sub> x 10 <sup>3</sup> / <sub>4</sub>

Design and specifications subject to change without notice.  
Actual shipping weight may differ due to extra packing materials for product protection.

- **WARRANTY : 2 Year Parts and Labor Warranty  
Additional 3 Year Warranty on Compressor**
- **SIMPLE PLUG-IN INSTALLATION**
- **PATENTED SELF-CONTAINED SYSTEM, NO PLUMBING REQUIRED**

■ TOMD-60-L : 60" Non-Refrigerated top display case for Low Profile	
Ext. Dimension (L x D x H)	63 <sup>1</sup> / <sub>4</sub> x 12 <sup>1</sup> / <sub>4</sub> x 13 <sup>1</sup> / <sub>4</sub>
Int. Dimension (L x D x H)	60 <sup>3</sup> / <sub>4</sub> x 9 <sup>1</sup> / <sub>8</sub> x 11 <sup>3</sup> / <sub>8</sub>
Cu. ft	3.6
Crated Weight lbs.	80

## PLAN VIEW

(unit : inch)

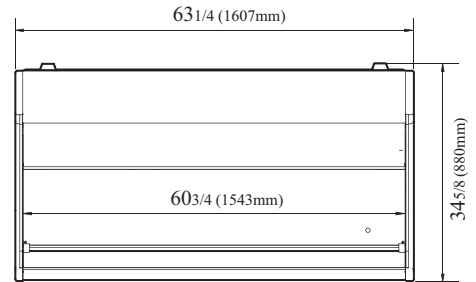

## TOP VIEW

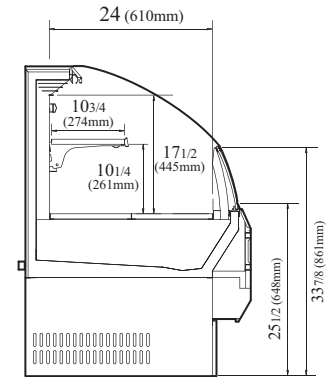

## SIDE VIEW

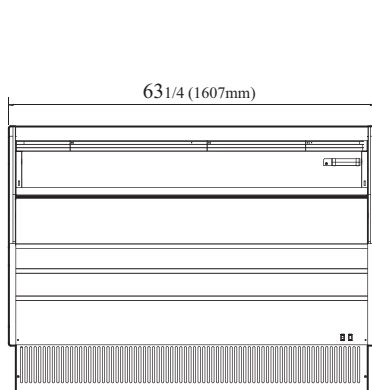
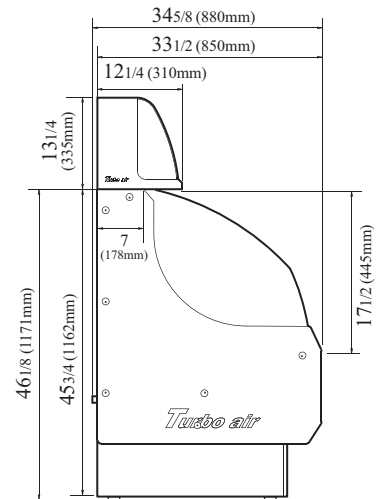

FRONT VIEW

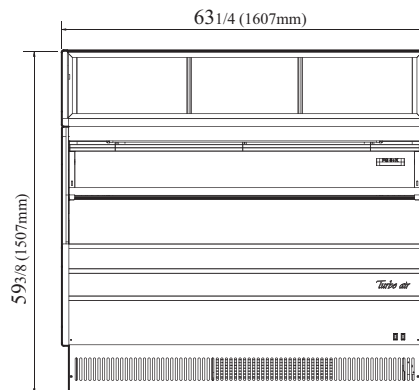

FRONT VIEW (W/ TOMD)

SIDE VIEW (W/ TOMD)

Ver.201401



- Turbo Air : 800-627-0032 ■ GK : 800-500-3519
- Warranty : 800-381-7770 ■ AC : 888-900-1002

REFRIGERATOR MANUFACTURER  
**Turbo air**

**GERMAN KNIFE**

**RADIANCE**

**GREEN WORLD**

AIR CONDITIONER MANUFACTURER  
**Turbo air**